

Prismen

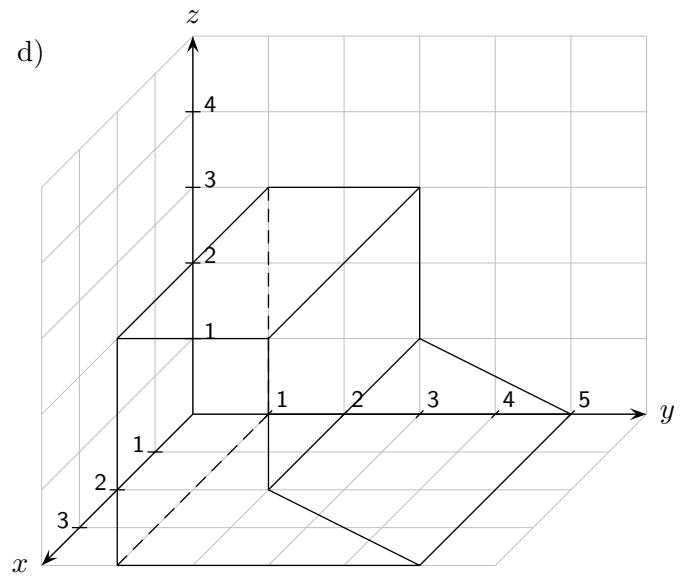

Roofs

Prismen

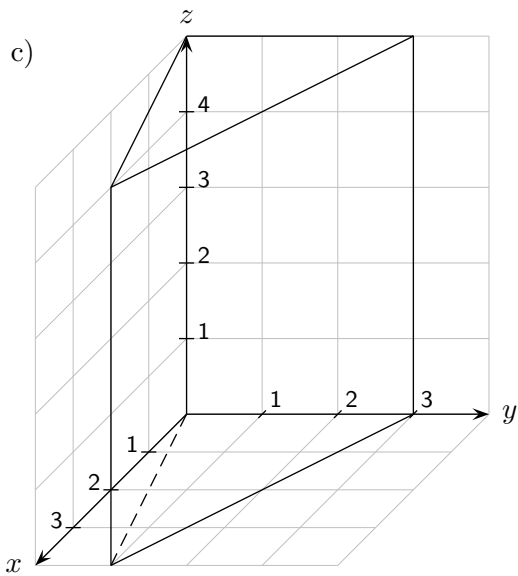
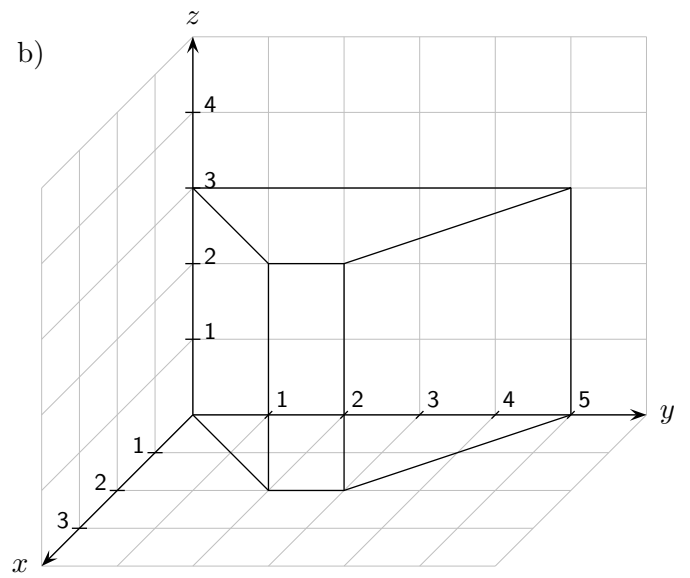
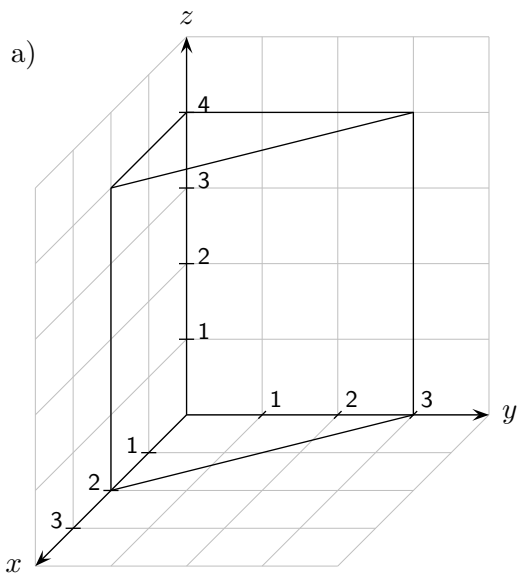
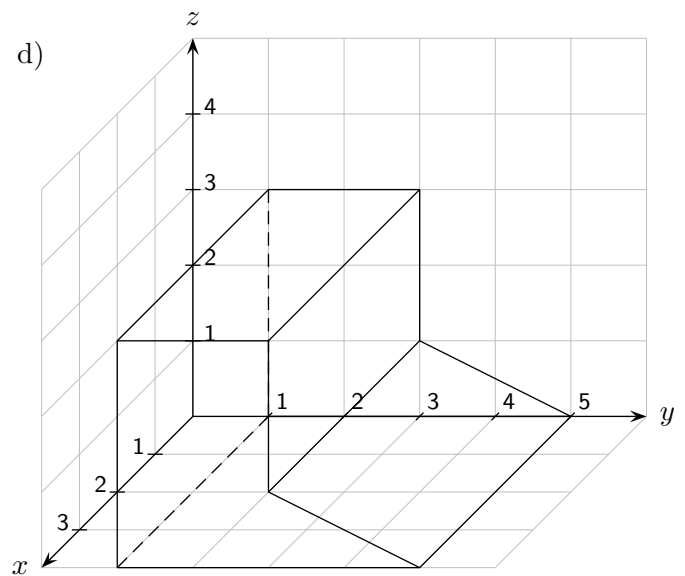
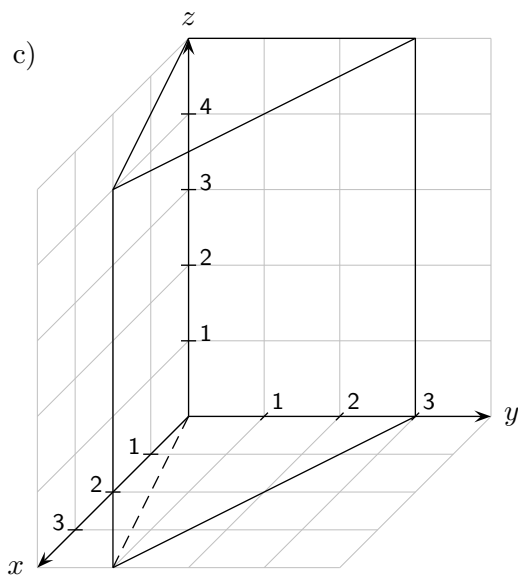
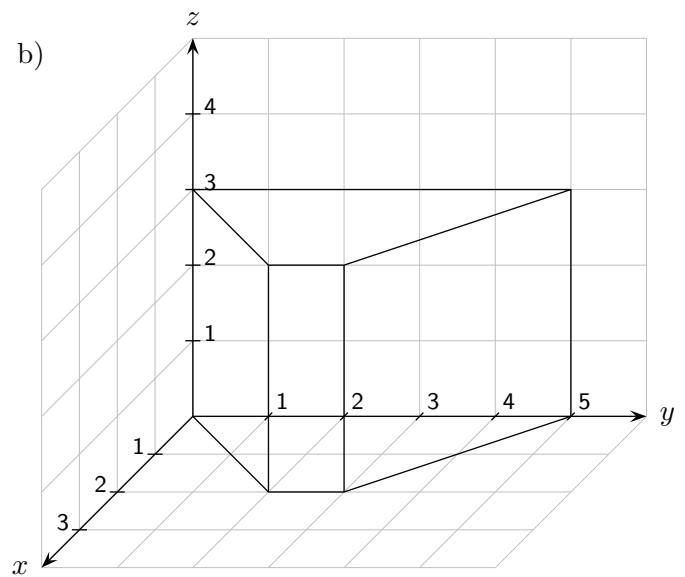
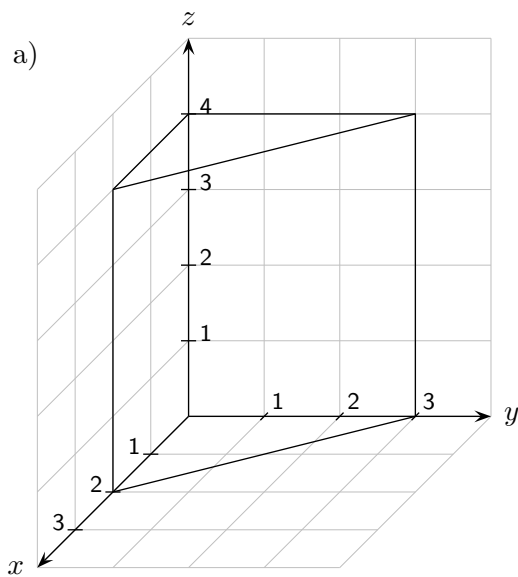

a) $G = 3 \text{ cm}^2$ (Grundfläche G), $U = 8,606 \text{ cm}$ (Umfang der Grundfläche U), U und O in Klasse 8
 $V = 12 \text{ cm}^3$ (Volumen V), $O = 40,422 \text{ cm}^2$ (Oberfläche O), $O = U \cdot h + 2 \cdot G$

b) $G = 6 \text{ cm}^2$, $U = 11,657 \text{ cm}$
 $V = 18 \text{ cm}^3$, $O = 46,971 \text{ cm}^2$

c) $G = 6 \text{ cm}^2$, $U = 11,595 \text{ cm}$
 $V = 30 \text{ cm}^3$, $O = 69,976 \text{ cm}^2$

d) $G = 7 \text{ cm}^2$, $U = 13,236 \text{ cm}$
 $V = 28 \text{ cm}^3$, $O = 66,944 \text{ cm}^2$

Prismen

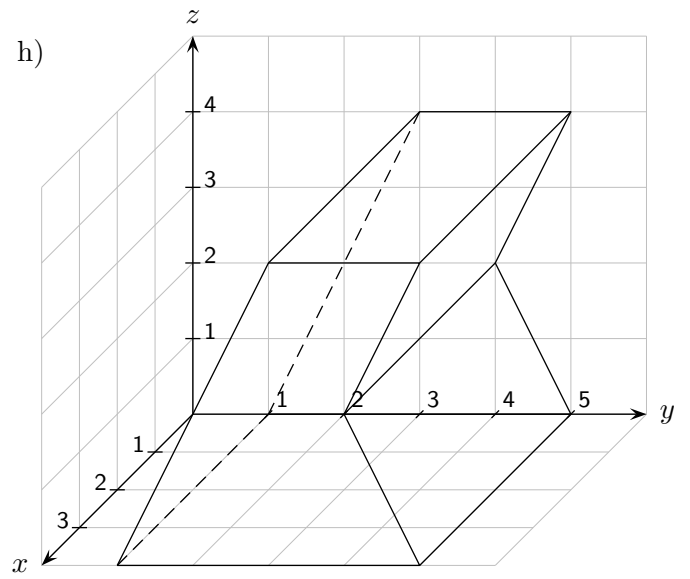
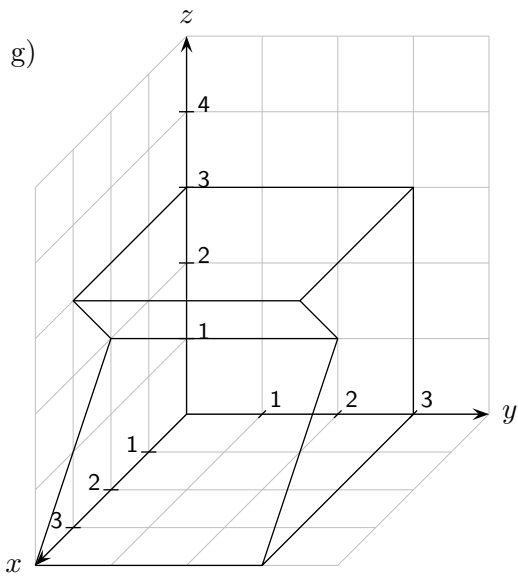
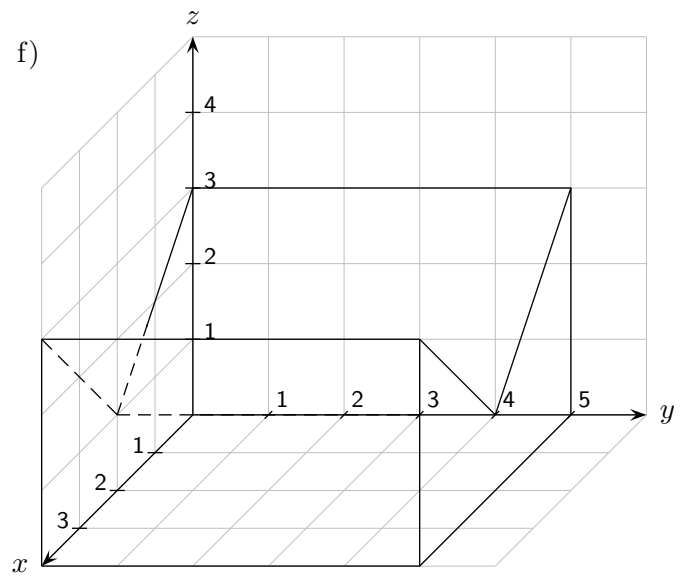
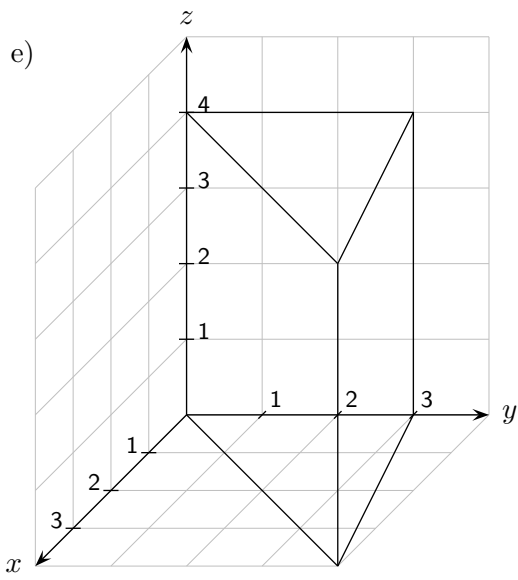

Prismen

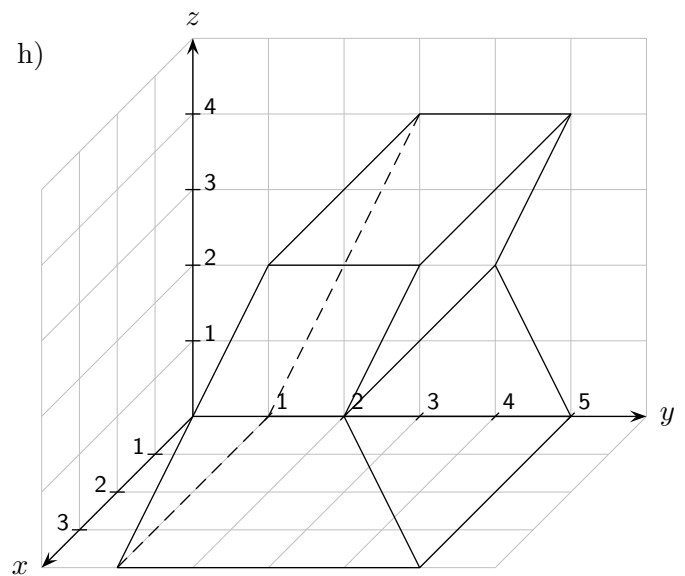
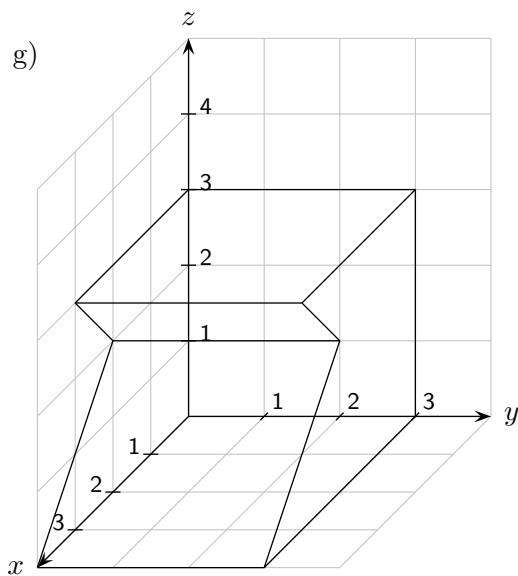
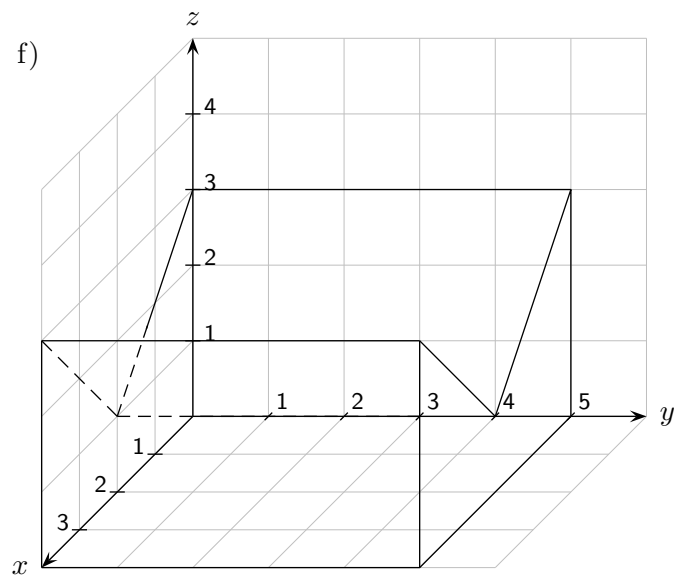
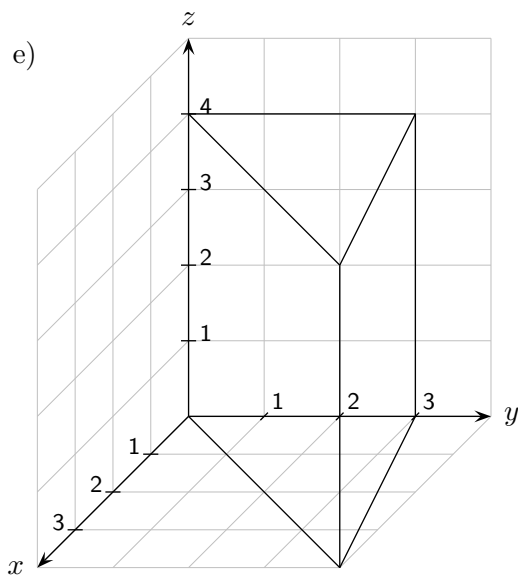

e) $G = 6 \text{ cm}^2$ (Grundfläche G), $U = 12,780 \text{ cm}$ (Umfang der Grundfläche U), U und O in Klasse 8
 $V = 24 \text{ cm}^3$ (Volumen V), $O = 63,120 \text{ cm}^2$ (Oberfläche O), $O = U \cdot h + 2 \cdot G$

f) $G = 8 \text{ cm}^2$, $U = 15,657 \text{ cm}$
 $V = 40 \text{ cm}^3$, $O = 94,284 \text{ cm}^2$

g) $G = 8,5 \text{ cm}^2$, $U = 14,243 \text{ cm}$
 $V = 25,5 \text{ cm}^3$, $O = 59,728 \text{ cm}^2$

h) $G = 10 \text{ cm}^2$, $U = 14,944 \text{ cm}$
 $V = 40 \text{ cm}^3$, $O = 79,777 \text{ cm}^2$